

Instruction Manual

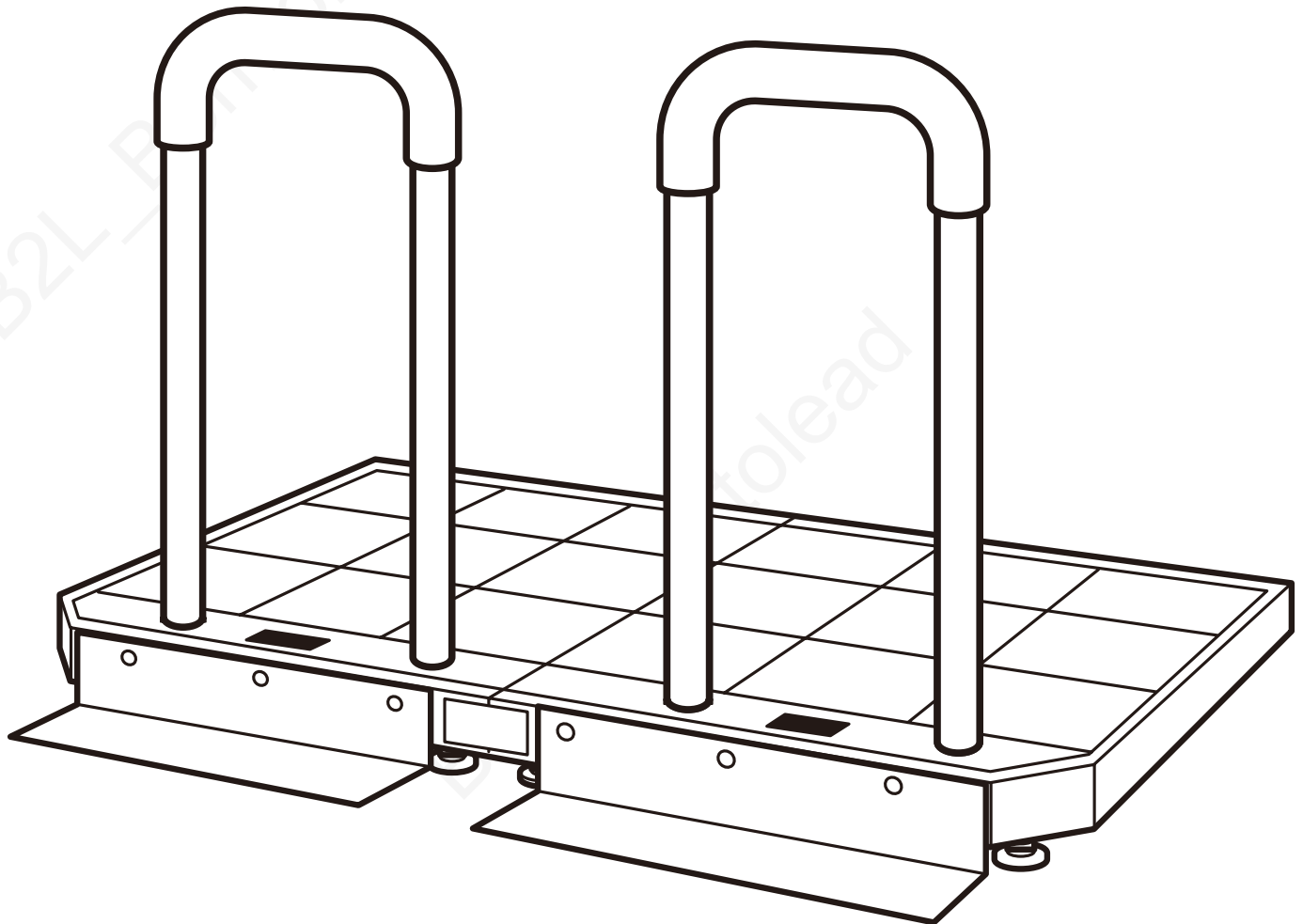

- The specifications of this product are subject to change without notice for performance improvements or other reasons

1 Specifications

How to connect the stage units

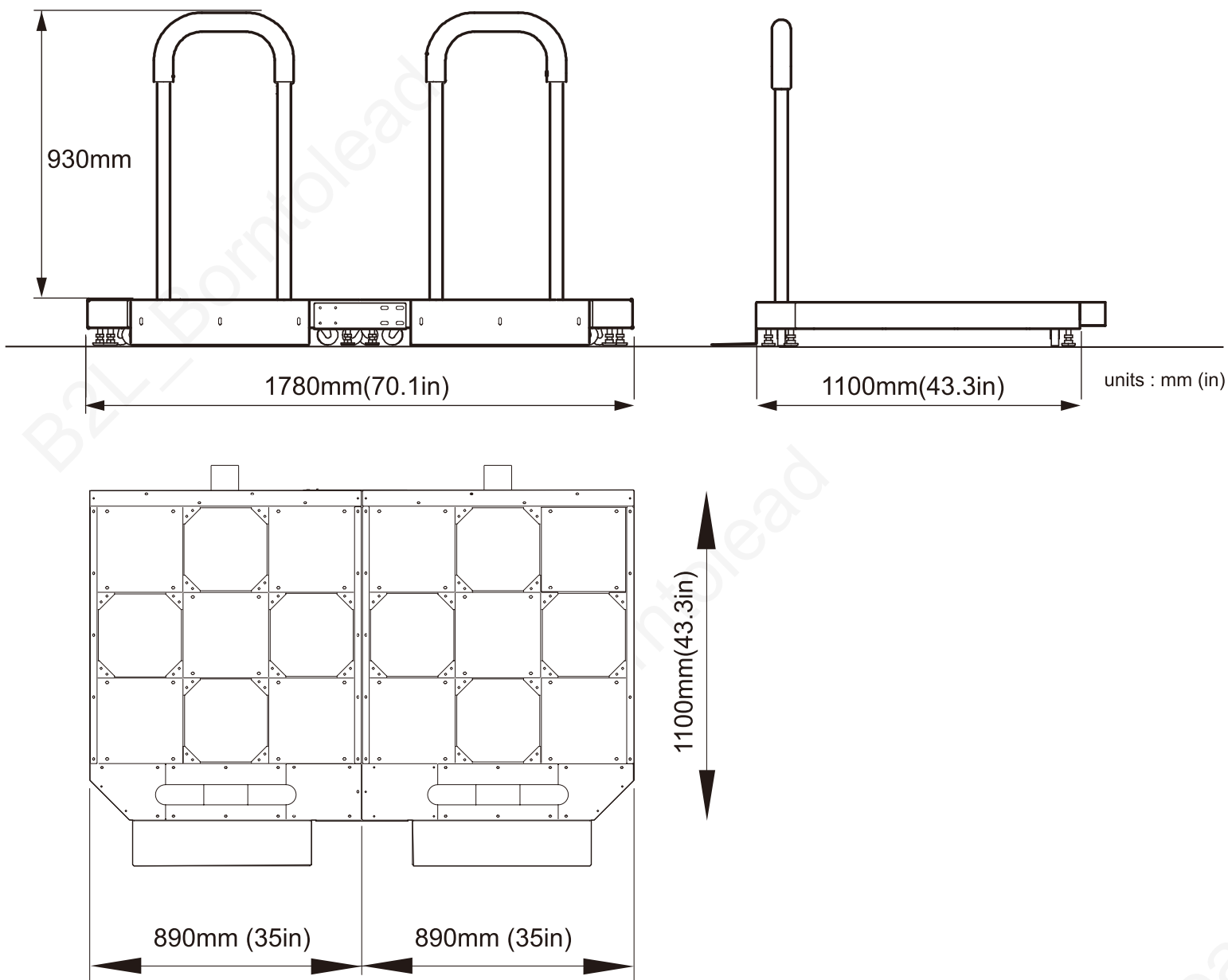





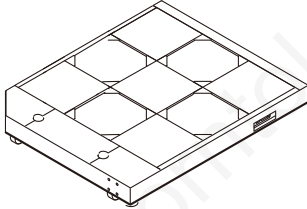
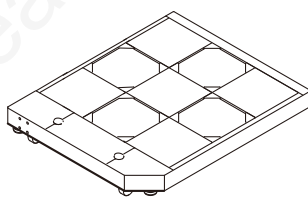
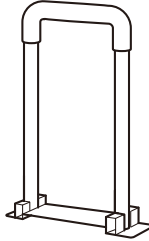
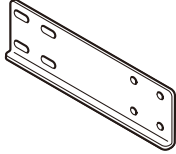
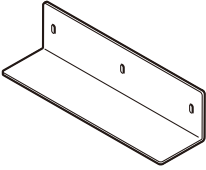
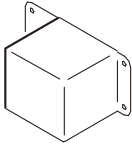
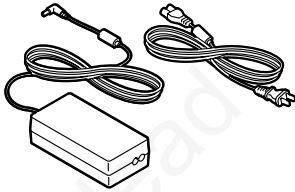
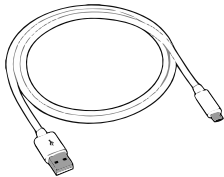
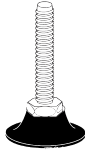

External dimensions	See the above figure
Dimensions when installed	Pad Left P1: 890mm x 1100mm x 90mm Pad Right P2: 890mm x 1100mm x 90mm Safety BAR: 930mm / Ø4.2mm
Main unit weight	Approx. 200 kg (when installed)
Conditions of Use	Ambient temperature 5~ 35°C/Ambient humidity 30~ 70% (no condensation)

- The specifications of this product are subject to change without notice for performance improvements or other reasons

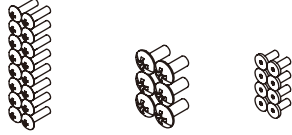
2 Parts and accessories

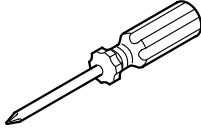
Part list

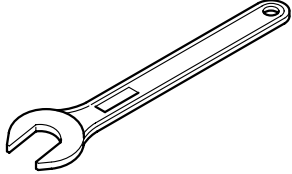
 <p>Step unit (R)</p>	 <p>Step unit (L)</p>	 <p>Safety bar x 2</p>	 <p>Joint bracket x 2</p>
 <p>Arcade Stage Plate x 2</p>	 <p>Metal box x 2</p>	 <p>12V3A Power adapter x 2</p>	<p>Length 1.8M/6FT</p>  <p>USB3.2 Gen1 AM to CM cable x 2</p>
 <p>Leg Leveler x 8</p>	 <p>Caster x 8</p>	 <p>Spare screws</p>	 <p>Hexagon Key Wrench Tool kit</p>
 <p>Philip screwdriver X 1</p>	 <p>Protection globes X 2 pair</p>	 <p>Wrench x1</p>	

3 Names of parts

Parts of the stage units

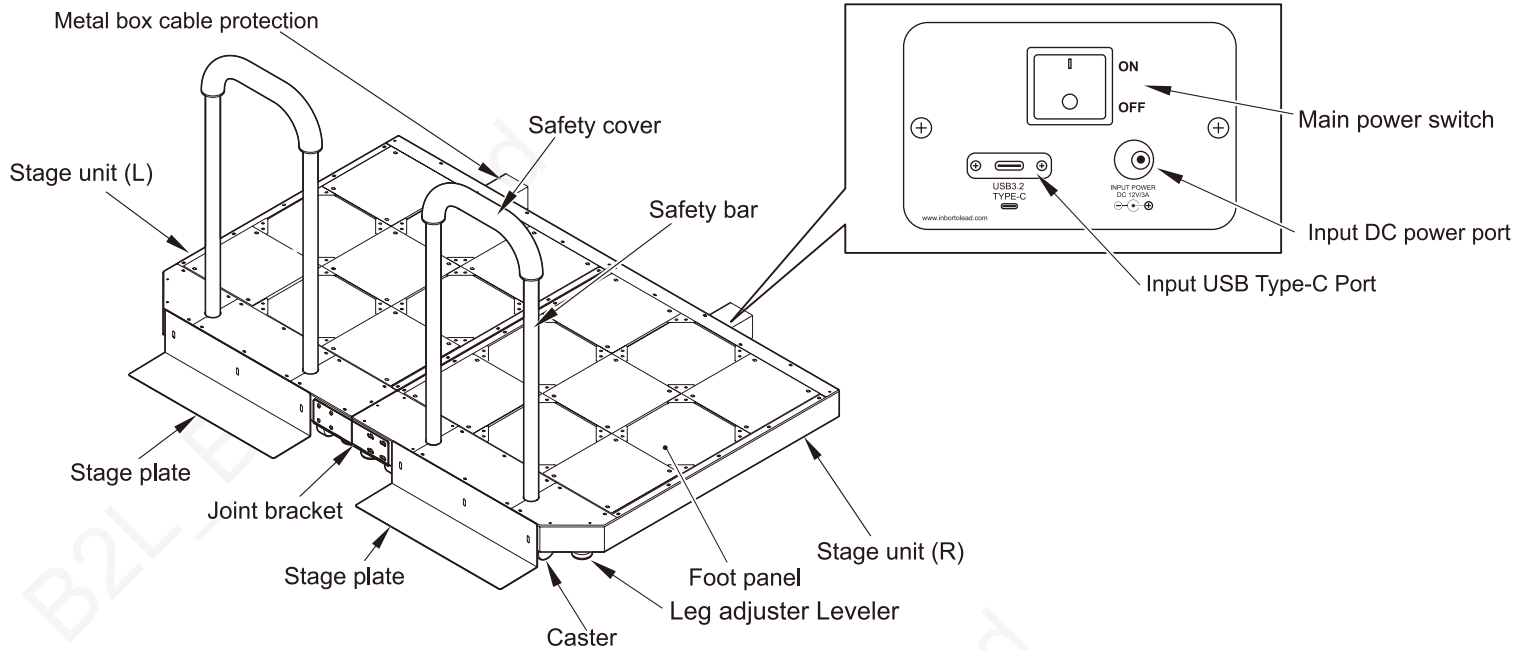

Parts of the stage units

SEPARATE SWITCH	<p>There are four cable switches on one foot panel. Step on each foot panel to check the reaction. The position of the cable switch that is detected is displayed.</p>
U D L R	<ul style="list-style-type: none"> • U.....The UP panel switch is detected. • D.....The DOWN panel switch is detected. • L.....The LEFT panel switch is detected. • R.....The RIGHT panel switch is detected.

- If the cable switch reacts even though you are not stepping on the foot panel, it is possible that sand or foreign objects are in the panel. Remove them.

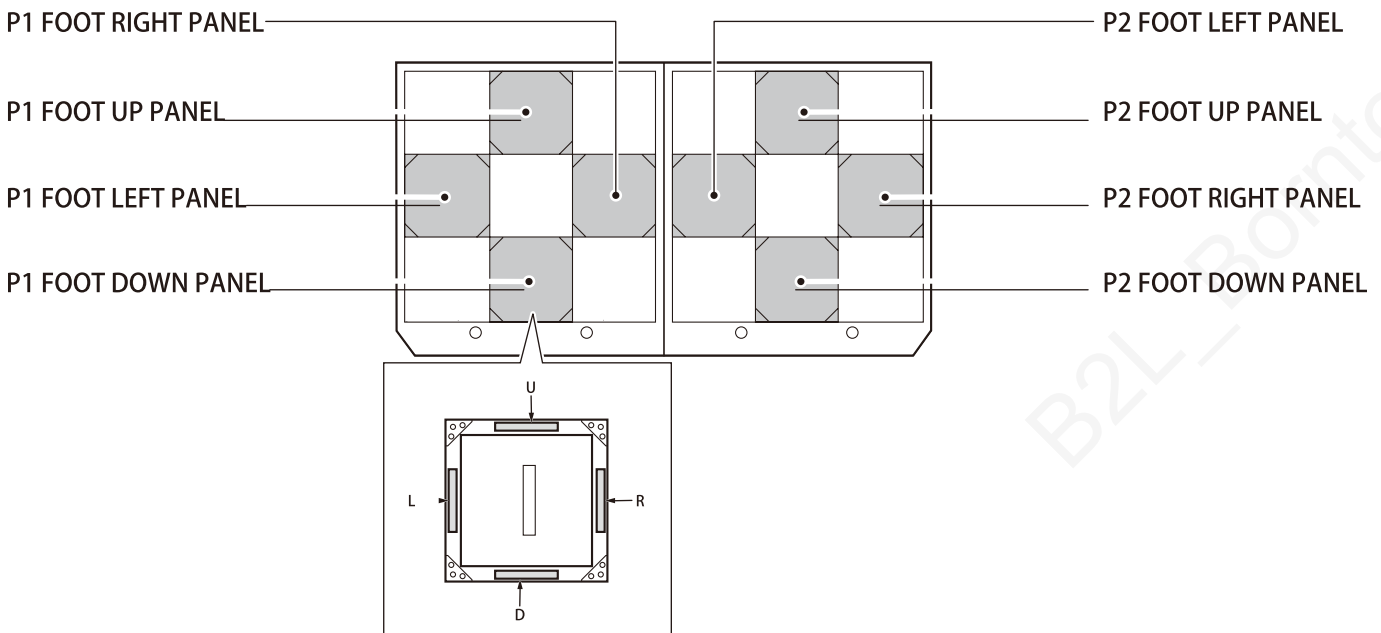

4 Installation and assembling

How to assembly the stage units

- 1 Install the caster
- 2 Install the Leg adjuster Leveler

Stage units

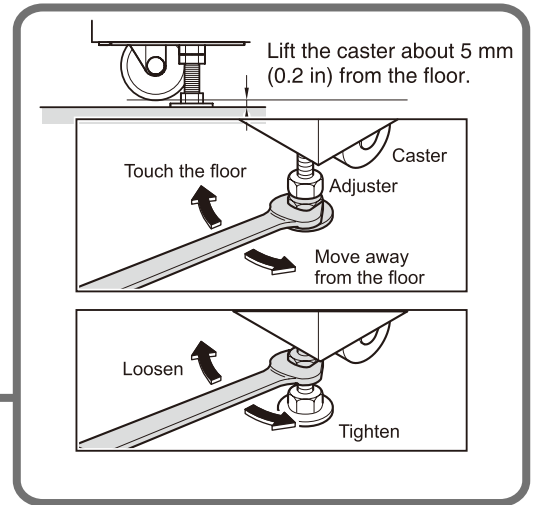
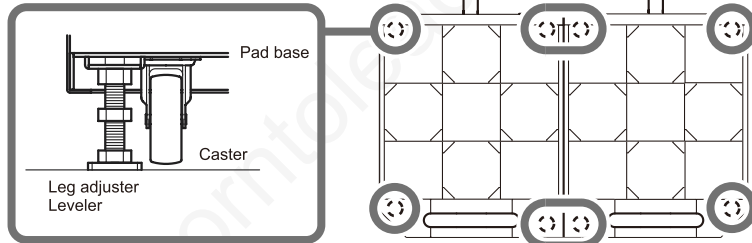

- 3 Remove plates shown in the figure from the stage units.
- 4 Install the safety bar
- 5 Reinstall the plates removed in step 3 above.
- 6 Connect the right and left stage units at two points with the joint brackets

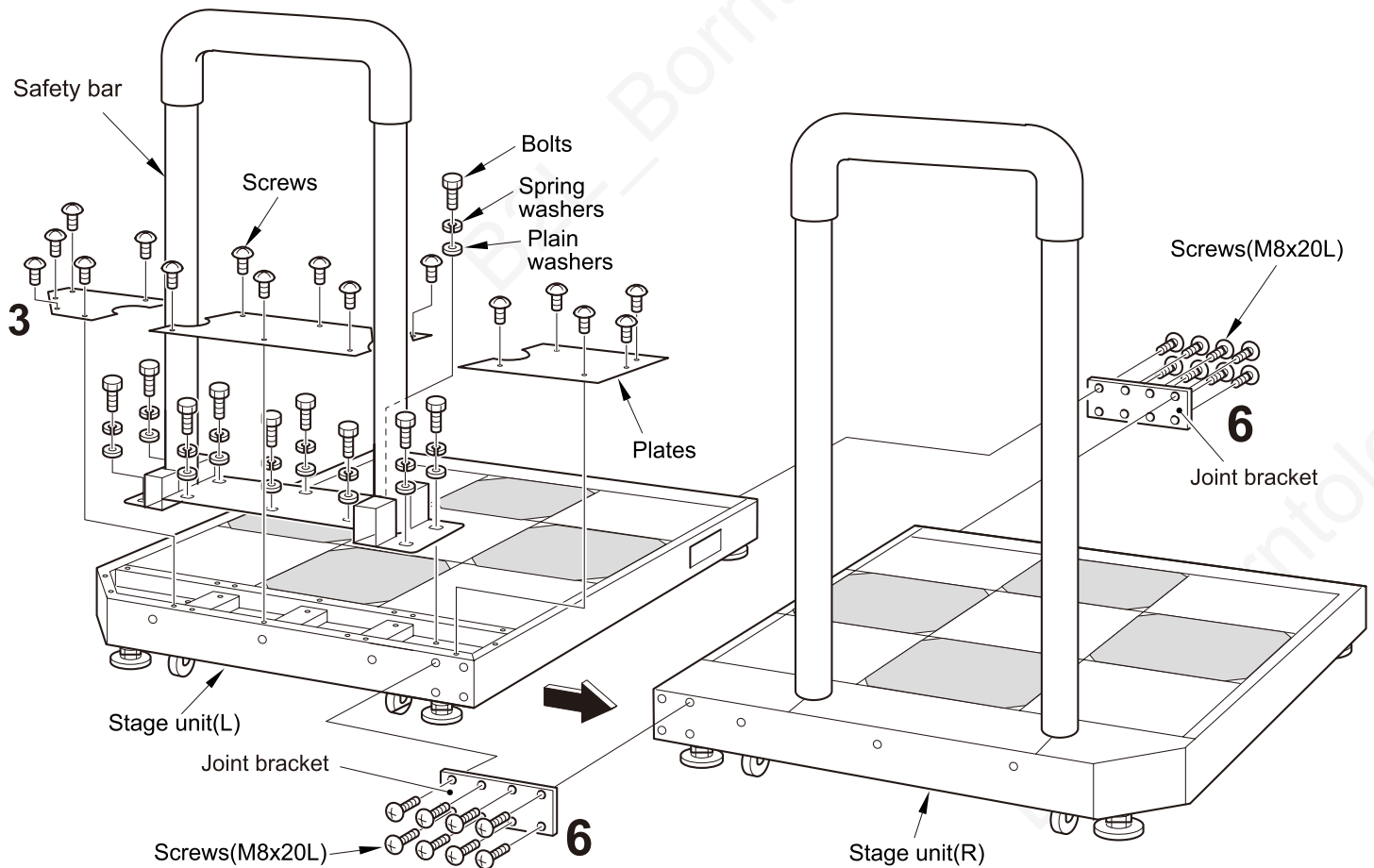

5 Installation and assembling

How to mount the stage plates

- Be sure to mount the stage plates which effectively prevent the stage unit from lifting.
- Mount the stage plate after the fixation of adjusters of each unit.

• Mount the stage plate after the completion of the installation of the caster and the adjusters.

• Be sure to remove the stage plates when moving the units

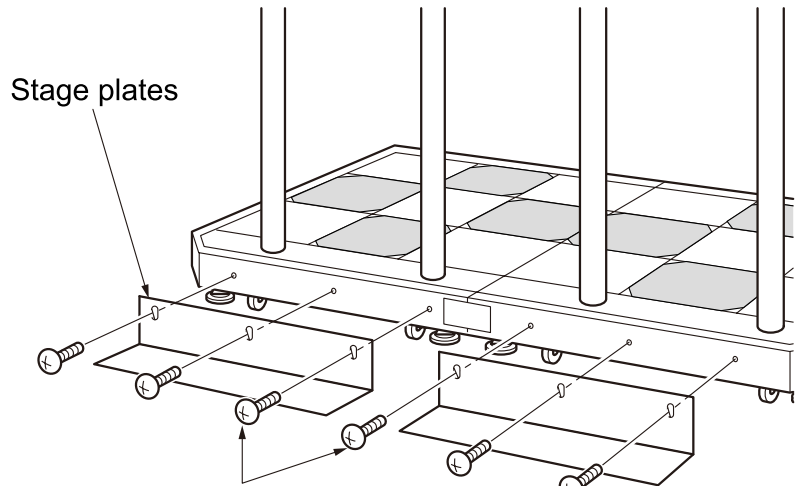

- Stage plate mounting screws
- Tighten the screws with the bottom face of stage plate being in contact with the floor.

How to connect to the PC

Connect the USB Cable:

- Plug one end of the USB cable into the each stage unit. (USB Type-C)
- Connect the other end of the USB cable to your PC/LAPTOP. (USB A Standard)

Connect the Power Adapter:

- Insert the power adapter into the each stage unit.
- Plug the power adapter into a wall outlet support (110V/220V)

Power On the Device:

- Turn on the stage unit using the power switch.
- Your stage unit should now be connected and powered on.

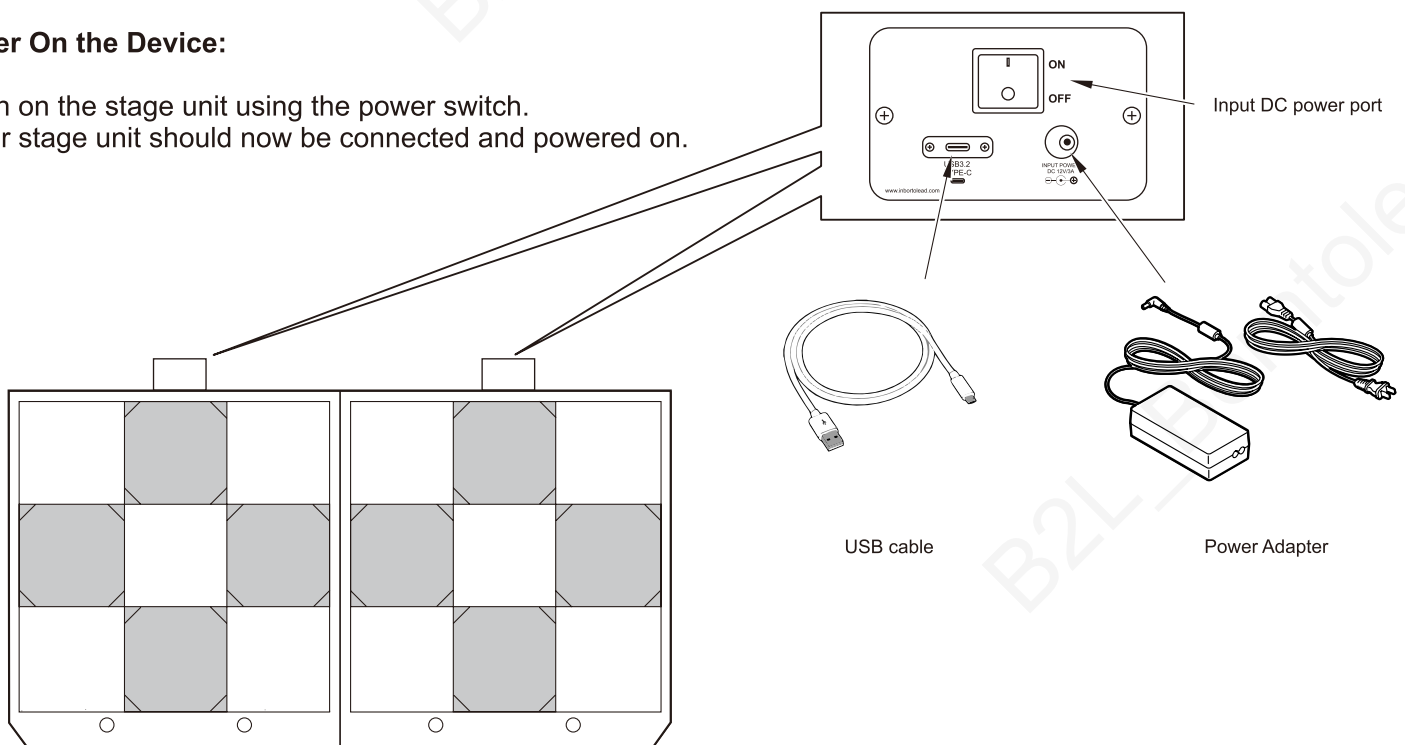

Warranty Terms and Conditions

Warranty Period: 365 days from the date of delivery.

Our company warrants compliance with the following aftermarket terms.
Please note that this warranty does not cover the accessories associated with this product.

- **Within 1-7 Days from Receipt of Delivery:** Upon receiving the product, if any issues arise, we will provide complimentary maintenance and replacement, and we will also cover the shipping costs.
- **Within 8-30 Days from Receipt of Delivery:** Provided the product is used under normal conditions, we will offer free maintenance and replacement. Shipping costs will be the responsibility of the customer.
- **Within 31-180 Days:** We will offer technical support via email and complimentary maintenance. Costs associated with replacement and shipping will be borne by the customer.
- **Within 181-360 Days:** We will provide technical support via email. Maintenance, replacement, and shipping costs will be the responsibility of the customer.
- **Beyond 360 Days:** We will only provide technical support via email. All other costs will be borne by the customer.

Exclusions:

This warranty does not cover the following scenarios, and any services provided will be charged accordingly:

- Failure to provide an order number when requesting maintenance.
- Products purchased second-hand.
- Damage resulting from fire, earthquake, flood, public disturbances, lightning strikes, salt corrosion, or other natural disasters.
- Damage caused by dropping or impacting the product during shipment or movement.
- Damage due to incorrect connection methods or operations not in accordance with the provided guide.
- Damage resulting from operations not adhering to specified notices.
- Damage caused by unauthorized modifications.
- Please let me know if you need any further adjustments!



<https://www.facebook.com/b2l.borntolead>



https://www.instagram.com/b2l_borntolead/



https://twitter.com/B2L_Borntolead



https://www.youtube.com/@b2l_borntolead



info@iborntolead.com

